



Dedicated Oil Coolers – DOC™

Brazed Plate Heat Exchangers



Working principles

The heating surface consists of thin corrugated metal plates stacked on top of each other. Channels are formed between the plates and corner ports are arranged so that the two media flow through alternate channels, normally in full counter-current flow. The media are kept in the unit by a brazed seal around the edge of the plates. The contact points of the plates are also brazed to withstand the pressure of the media handled.

Standard design

The plate pack is covered by the cover plates. The connections are located in the front cover plate. The channel plates are corrugated to improve heat transfer efficiency and to increase the mechanical strength.

Standard materials

Cover plates: Stainless steel 304
Connections: Stainless steel 304
Plates: Stainless steel 316
Brazing material: Copper

Particulars required for quotation

To enable Alfa Laval's representative to make a specific quotation, enquiries should be accompanied by the following particulars:

- Flow rates required
- Temperature program
- Physical properties of liquids in question
- Desired working pressure
- Maximum permitted pressure drops

Technical data for Dedicated Oil Coolers

Standard data

	DOC14	DOC20	DOC30	DOC60	DOC77	DOC77HF
Max. working temperature	225°C	225°C	225°C	225°C	225°C	225°C
Min. working temperature	-196°C	-196°C	-196°C	-196°C	-196°C	-196°C
Max. working pressure						
S1-S2/S3-S4, bar	33/33	16/16	33/33	40/40	16/30	16/30
Min. working pressure	Vacuum	Vacuum	Vacuum	Vacuum	Vacuum	Vacuum
Volume per channel, litres	0.02	0.028	0.05	0.103	0.25	0.25
Cooling capacity, kW	< 16	6-75	10-100	20-140	40-170	120-360
Standard number of plates	14, 20	20, 40, 60, 90, 110	10, 18, 24, 34, 50, 70, 100	20, 30, 40, 50, 60, 70, 80	20, 30, 40, 50	60, 70, 80, 90, 100

Dimensions

Type	a	b	c	d	e	A	Dry weight, kg
DOC14	172	42	208	78	22	$8 + n \times 2.25$	$0.8 + n \times 0.06$
DOC20	270	46	324	94	26	$8 + n \times 1.50$	$1.5 + n \times 0.08$
DOC30	250	50	313	113	26	$9 + n \times 2.35$	$2.4 + n \times 0.10$
DOC60	466	50	527	113	26	$13 + n \times 2.35$	$2.1 + n \times 0.18$
DOC77	519	92	618	191	26	$10 + n \times 2.85$	$11.0 + n \times 0.44$
DOC77HF	519	92	633	191	26	$10 + n \times 2.85$	$13.0 + n \times 0.44$

n = number of plates

Connections

Type	S1-S2, oil	S3-S4, water	Spanner grip	f
DOC14	ISO-G 3/4"	ISO-G 3/4"	32	M8
DOC20	ISO-G 1"	ISO-G 3/4"	41	M8
DOC30	ISO-G 1 1/4"	ISO-G 3/4"	50	M8
DOC60	ISO-G 1 1/4"	ISO-G 3/4"	50	M8
DOC77	ISO-G 1 1/2"	ISO-G 1"	80	M8
DOC77HF	SAE 2 1/2"	ISO-G 1 1/4"	114	M10

Support bracket dimensions

Type	L	L1	L2	L3	L4	w	t	Ø
DOC14	177	57	119	44	78	20	5	9
DOC20	275	85	189	51	94	25	6	9
DOC30	255	75	179	58	100	25	6	9
DOC60	471	75	395	58	100	25	6	9
DOC77	524	149	372	106	180	25	8	11
DOC77HF	524	149	372	106	180	25	8	11

Nipple connections (optional)

DOC14, 20, 30, 60	ISO-G 1/2" int. thread
DOC77, 77HF	ISO-G 1" int. thread

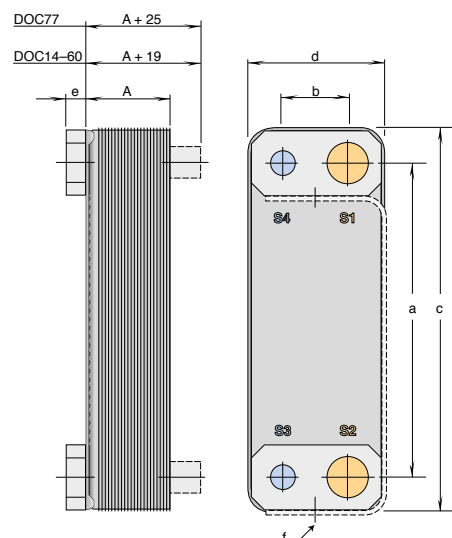

DOC dimensioning

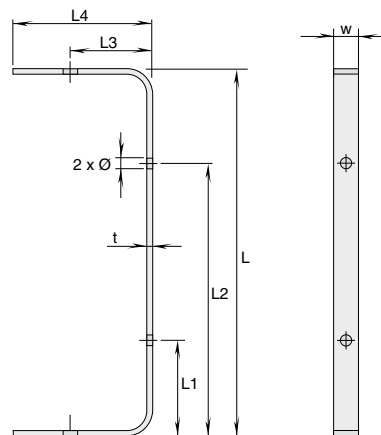

Support bracket

EFU00039EN 1005

Alfa Laval reserves the right to change specifications without prior notification.

How to contact Alfa Laval

Up-to-date Alfa Laval contact details for all countries are always available on our website at www.alfalaval.com